

Introduction to Cryptography

The Basics



- Modern cryptography is a branch of applied mathematics
- About 100 years ago, cryptanalysts were using group theory and permutation theory—and the amount of math used has increased dramatically since then
- (One of the reasons for the British success during World War II at Bletchley Park (and the Poles before them): they hired mathematicians, rather than the linguists employed as cryptanalysts during World War I)
- Consequently, this unit will have far more math than the rest of the course

What is “Cryptography”?

- Literally: “secret writing” (from Latin roots)
- (Purists call the subject “cryptology”, which includes cryptography, cryptanalysis, etc.)
- Historically, cryptography was used for confidentiality: keeping messages secret
- Encryption goes back thousands of years
- Today, we do much more, including authentication, integrity-checking, “signing” documents, playing games of chance over the Internet, cryptocurrencies like Bitcoin, etc.

The Caesar Cipher

We'll start by using historical, pen-and-paper ciphers on ordinary letters—it's easier to see what's happening, and the principles are the same.

Replace each letter with the one three down in the alphabet:

A	B	C	...	X	Y	Z
↓	↓	↓	↓	↓	↓	↓
D	E	F	...	A	B	C

- According to Suetonius, this cipher was used by Julius Caesar
- But why did he shift by 3? Could he have used a different number?

Systems and Keys

- In modern terminology, encryption is done with an *algorithm* and a *key*
- For Caesar, the algorithm was

$$(P_i + K) \bmod 23 \rightarrow C_i$$

where P_i is a character of the *plaintext*, C_i is the corresponding *ciphertext* character, and K is the key

- (The classical Latin alphabet had 23 letters: no J, U, or W. . .)
- The key K was fixed at 3
- (We sometimes say it used a key of 'D', because it mapped A→D).



$plaintext \xrightarrow{\text{encryption}} ciphertext \xrightarrow{\text{decryption}} plaintext$

- *plaintext, cleartext* — original message
- *ciphertext* — mangled information
- *key* — additional information used for encryption and decryption

Codes and Ciphers

- *Ciphers* operate on *syntactic* elements, e.g., letters or groups of letters
- *Codes* operate on semantic elements, e.g., words, phrases, and sentences
- The output of a codebook can be *superenciphered* for greater security
- Commercial codebooks were used for compression—telegraph companies charged by the word—but provided some security from casual eavesdroppers
- Through World War II, though, most governments and militaries used stronger codes for confidentiality
- (Codes are no longer used seriously)



228 GENERAL PHRASES.

Grugasso	Crossing the Atlantic Ocean.
Grugount	Crossing " Pacific
Grugnire	Crossing " Indian "
Grunal	Crossing from here to
Grullas	Letters crossed each other.
Grumar	Telegrams " " "
Grumo	CRUISE.
Grumolo	A summer cruise.
Grumosa	A yachting " "
Grumosos	Away on a " in ———,
Grumpily	Away " " yachting cruise.
Grumulis	Going " " "
Grundig	A week's cruise.
Grundios	A few days' "
Grunido	A month's "
Grunimos	For ——— months' cruise.
Gruppen	For a short cruise.
Gruseln	For a long "
Grutesca	For a cruise.
Gruttos	A cruise to the
Gudone	A " " " Mediterranean.
Gualoita	A " " " West Indies.
Gualdo	A " " " tropics.
Guanca	On a cruise.
Guanca	On a yachting cruise.
Guspico	Will leave on ——— for a cruise (in ———).
Guspos	Fitting out for a cruise.
Guarapo	Fitting " " " short cruise.
Guardago	Fitting " " " long "

(from the 1896 *Atlas Universal Travelers' and Business Telegraphic Cipher Code*)

A cryptosystem is a pair of functions, E and D , such that:

$$C \leftarrow E(P, K)$$

$$P \leftarrow D(C, K')$$

$$P = D(E(P, K), K')$$

where P is the plaintext, C is the ciphertext, E is the encryption function, D is the decryption function, and K and K' are keys. Often, $K' = K$; sometimes, $K' = F(K)$.

Today, $K \in \{0, 1\}^l$, $P \in \{0, 1\}^m$, and $C \in \{0, 1\}^n$. The *keylength* is l , the input blocksize is m , and the output blocksize is n . Generally, $m = n$.

- A cryptosystem is pair of algorithms that take a *key* and under control of that key convert *plaintext* to *ciphertext* and back.
- Plaintext is what you want to protect; ciphertext should appear to be random gibberish.
- The design and analysis of today's cryptographic algorithms is highly mathematical. Do *not* try to design your own algorithms.

 I repeat: do NOT try to design your own algorithms; with rare exceptions, avoid any product that brags of their own, “highly secure” encryption algorithms

Essential Properties

- Without knowledge of K , inverting E should be infeasible. That is, *cryptanalysis* should be infeasible.
- That should be true even if the enemy has many $\langle P, C \rangle$ pairs, or even if the enemy can supply many P s to be encrypted
- The keylength l should be large enough that the enemy can not perform a *brute force* (also known as *exhaustive search*) attack on the key space.
- Assume that the enemy knows all details of your algorithm, but does not know the key (Kerckhoffs, 1883)
- Later, we'll discuss other necessary security properties for cryptosystems

- Must be strongly protected
- Ideally, should be a random set of bits of the appropriate length
- Ideally, each key should be used for a limited time only
- Ensuring that these properties hold is a major goal of cryptographic research and engineering

Brute-Force Attacks

- Build massively parallel machine
- Can be distributed across the Internet
- Give each processor a set of keys and a plaintext/ciphertext pair
- If no known plaintext, look for probable plaintext (i.e., length fields, high-order bits of ASCII text, etc.)
- On probable hit, check another block and/or do more expensive tests

CPU Speed versus Key Size

- Adding one bit to the key doubles the work factor for brute force attacks
- The effect on encryption time is often negligible or even free
- It costs *nothing* to use a longer RC4 key
- Going from 128-bit AES (Advanced Encryption Standard) to 256-bit AES takes (at most) 40% longer, but increases the attacker's effort by a factor of 2^{128}
- Using triple DES (Data Encryption Standard) costs 3× more than DES to encrypt, but increases the attacker's effort by a factor of 2^{112}
- Moore's Law favors the defender

Caesar Ciphers and their Keys

- Julius Caesar (supposedly) never changed his key; if the key was ever recovered, there would be no more secrecy
- A brute force attack on 22 possible keys wouldn't take long, even by hand
- But: were his enemies even literate? Pompey and his officers almost certainly could read, but what about Caesar's enemies in Gaul?
- (Al-Kindi published a ground-breaking work on cryptanalysis circa 850 in Baghdad—but that implies that he encountered sophisticated methods of encryption. Al-Khalil wrote a (now-lost) book on cryptography in Basra about 75 years earlier.)

Monoalphabetic Cipher

- A *monoalphabetic cipher* always maps the same plaintext symbol (letter) to the same ciphertext symbol.
- Many characteristics, e.g., letter frequencies, show through
- Solving these by hand is easy
- In a good cipher, the output frequency is *flat*
- In other words, we want high entropy: it should be indistinguishable from true-random

English Letter Frequencies

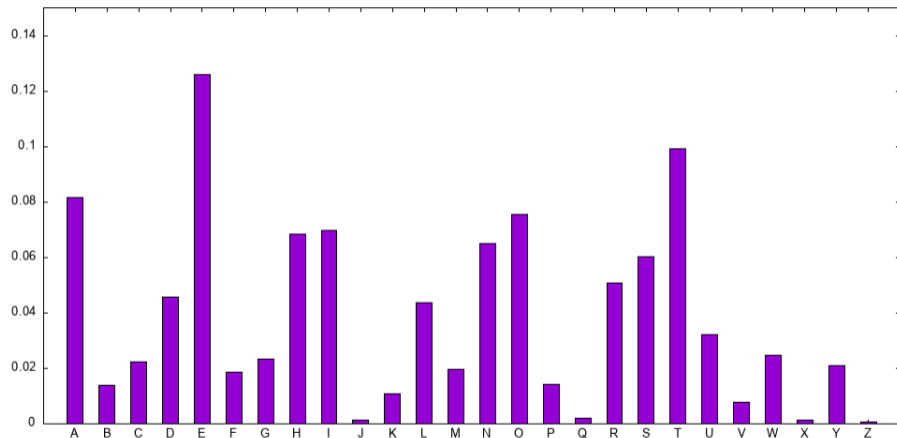

(Data taken from *Alice's Adventures in Wonderland*)

Entropy (Shannon, 1948)

- *Entropy* measures the amount of disorder—randomness—in a set
- Entropy is usually measured in bits: $\log_2 26 \approx 4.70$ if all letters were equally probable
- Lack of randomness aids cryptanalysis
- Simple Caesar (or other substitution) ciphers do not increase entropy:

```
$ entropy alice.txt
```

```
4.161
```

```
$ caesar alice.txt | entropy
```

```
4.161
```

```
$ substitute -k VKQCTDRSBJUNPEOFAIZGMWXYLH alice.txt | entropy
```

```
4.161
```

Shannon, Information Theory, and Entropy

- During World War II, Claude Shannon worked on SIGSALY, a voice encryptor
- This led him to invent *information theory*, and publish mathematical formalizations of communications and secrecy
- A fundamental issue: how much *information* does a message contain?
- Example: if you flip a coin 100 times and get “heads” 99 times, an “H” carries very little information. But a “T” carries a lot.
- English is *redundant*—you don’t need every letter
- Start of an old subway ad: “F U CN RD THS...”

$$-\sum_{i=1}^n P(x_i) \log_2 P(x_i)$$

Shannon on Encryption

Shannon, “A Mathematical Theory of Secrecy”:

In a secrecy system there are two statistical choices involved, that of the message and of the key. We may measure the amount of information produced when a message is chosen by $H(M)$:

$$H(M) = - \sum P(M) \log P(M),$$

the summation being over all possible messages. Similarly, there is an uncertainty associated with the choice of key given by:

$$H(K) = - \sum P(K) \log P(K).$$

Information and uncertainty are maximized when the distributions are flat.

Increasing Entropy: Longer Keys

- Use a different key for different letters of the plaintext
- Example: Vigenère cipher—repeat a keyword as necessary; encrypt each letter with the appropriate letter of the keyword

J	U	D	G	E	J	U	D	G	E	J	U	D	...
⊠	⊠	⊠	⊠	⊠	⊠	⊠	⊠	⊠	⊠	⊠	⊠	⊠	
A	L	I	C	E	S	A	D	V	E	N	T	U	...
↓	↓	↓	↓	↓	↓	↓	↓	↓	↓	↓	↓	↓	
J	F	L	I	I	B	U	G	B	I	W	N	X	...

- The two As are encrypted differently—but the two Es happen to be encrypted with the same key letter

```
$ vigenere -k JUDGE alice.txt | entropy  
4.626
```

Increasing Entropy: Longer Encryption Blocks

Longer encryption blocks flatten frequency distribution ($\log_2 26^2 \approx 9.4$)

Caesar Digraph Frequency

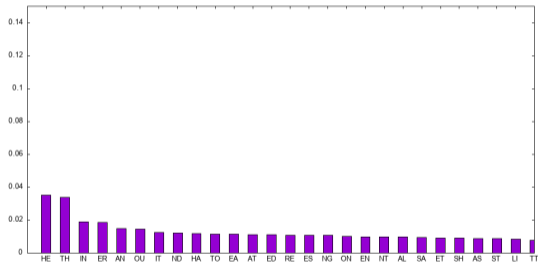

Playfair Digraph Frequency

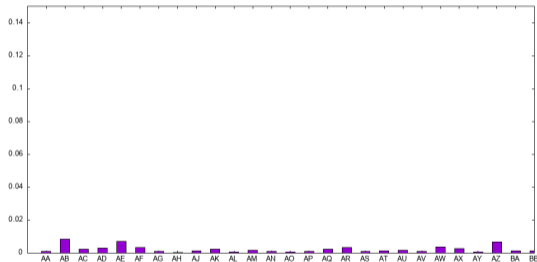

```
$ caesar alice.txt | entropy -n 2  
7.693
```

```
$ playfair -k MYVOW alice.txt | \  
entropy -n 2  
8.599
```

Increasing Entropy: Transposition

Transposition cipher: rearrange the order of the letters by transposing a matrix, to break up common letter sequences, e.g., THE and ING

Example: $k = 5 \times 4$

A	L	I	C	
E	S	A	D	
V	E	N	T	→ AEVUI ... LSERN ... IANEW ... CDTSO
U	R	E	S	
I	N	W	O	

```
$ transpose -k 4x17 alice.txt | entropy
```

```
4.162
```

```
$ transpose -k 4x17 alice.txt | entropy -n 2
```

```
8.320
```

```
$ transpose -k 4x17 alice.txt | entropy -n 3
```

```
12.386
```

Maximum Entropy

- We get maximum security if the key is truly random *and* is as long as the plaintext
- This is called the *one-time pad*, and is used by some spies, the Washington-Moscow hotline, etc
- One-time pads are guaranteed 100% secure—if the key is really random, i.e., not generated by an algorithm, and if it is never reused
- (Invented in 1882 by Frank Miller, a Sacramento banker; reinvented in 1919 by Gilbert Vernam and Joseph Mauborgne. It is unclear if Mauborgne knew of Miller's work.)

```
$ random -c 150000 >/tmp/random-key; entropy /tmp/random-key
4.700
$ otp -K /tmp/random-key alice.txt | entropy
4.700
$ otp -K /tmp/random-key alice.txt | entropy -n 2
9.396
```

Project Venona: Reading a Two-Time Pad...

- During World War II, the Soviets had trouble producing enough true-random one-time pads
- Some of their spies in the U.S. had duplicate pages
- American cryptanalysts detected this and were able to read traffic that should have been perfectly secure

Principles of Cipher Design

- Substitution
- Permutation
- Longer keys
- Encrypting blocks of plaintext

Most modern ciphers—which operate on bits and bytes, not ASCII letters—use combinations of these principles, and generally repeated combinations

```
$ vigenere -k JUDGE alice.txt | entropy
```

```
4.626
```

```
$ vigenere -k JUDGE alice.txt | entropy -n 2
```

```
8.918
```

```
$ transpose -k 4x17 alice.txt | entropy
```

```
4.162
```

```
$ transpose -k 4x17 alice.txt | entropy -n 2
```

```
8.320
```

```
$ vigenere -k JUDGE alice.txt | transpose -k 4x17 | entropy -n 2
```

```
9.211
```

Did We Get It Right?

Let's combine all three ciphers and see what we get

```
$ playfair -k SPHINX alice.txt | vigenere -k JUDGE | transpose -k 4x17
```

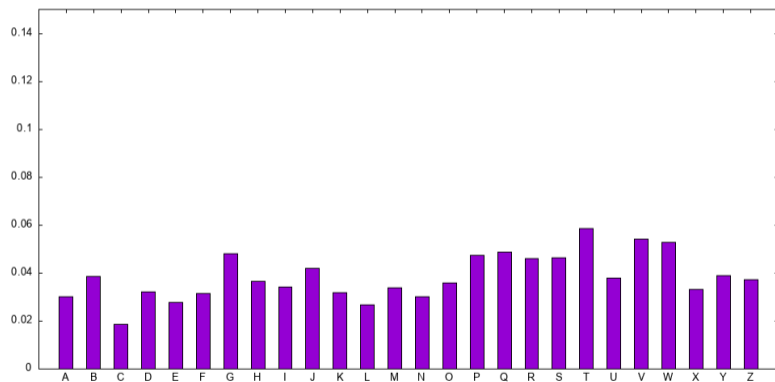

The frequency plot still isn't flat—and is that the only metric?

Once More, But Iterated and With More Key Material

```
$ playfair -k SPHINX alice.txt | vigenere -k JUDGE | transpose -k 4x17 | \
  playfair -k BLACKQUARTZ | vigenere -k MYVOW | transpose -k 13x5
```

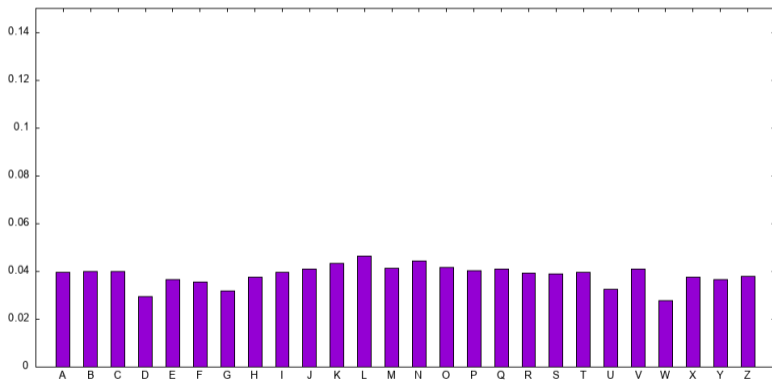

Noticeably better!

Limits to Security

- A cipher is no stronger than its key length: if there are too few keys, an attacker can enumerate all possible keys
- The old DES cipher has 56 bit keys — arguably too few in 1976; far too few today. (*Deep Crack* was built in 1996 by the EFF.)
- Strength of cipher depends on how long it needs to resist attack.
- No good reason to use less than 128 bits
- NSA rates 128-bit AES as good enough for SECRET traffic; 256-bit AES is good enough for TOP-SECRET traffic.
- But a cipher can be considerably weaker! (A monoalphabetic cipher over all possible byte values has 256! keys — a length of 1684 bits — but is trivially solvable.)
- Let's look at some modern designs

A Bit More History

- Until the 1970s, ciphers were designed by governments and amateurs—there was almost no private sector or academic interest (or competence)
- In 1972, the US and the Soviet Union negotiated a huge grain deal—and US intelligence later learned that the Soviets were eavesdropping on the American grain negotiators
- 👉 Protecting unclassified *civilian* traffic was now seen as a matter of national security
- The National Bureau of Standards (NBS) (now called NIST, the National Institute of Standards and Technology) put out a call for a modern, public encryption algorithm

Lucifer and DES

- There was only one submission: Lucifer, from IBM
- Lucifer encrypted 64-bit blocks under the control of a 112-bit key; there were 16 *rounds* (iterations)
- The basic structure was a *Feistel network*
- The design went to NBS, which shared it with NSA
- It came back changed: the S-boxes were different, and the key size was cut to 56 bits. . .
- The result became DES: the Data Encryption Standard

DES: The Data Encryption Standard

- DES was the first modern, public design
- DES is a *block cipher*—it operates on blocks of fixed length: 64 bits
- *Stream ciphers* operate on continuous sequences of bits or bytes (or, less commonly other lengths)
- A tremendous amount of academic cryptographic knowledge came from studying DES—it was, after all, an NSA-approved design
- Even though it's now obsolete, it's still worth studying, to understand how a modern cipher can be built

The Feistel Network

- An iterated design; for DES, there are 16 rounds
- The key is converted to a *key schedule*; there is a separate *subkey* for each round
- Each round contains a keyed substitution/permutation
- In each round, the two halves are swapped; one half is combined with the subkey in the F function, the output of which is in turn exclusive-ORed with the other half
- To decrypt, use the same key schedule, but go through the rounds in reverse-order
- (Spend some time understanding why that works. Briefly, exclusive-OR is its own inverse, and the swap/pass-through means that the correct data is XORed each time.)

DES Round Structure

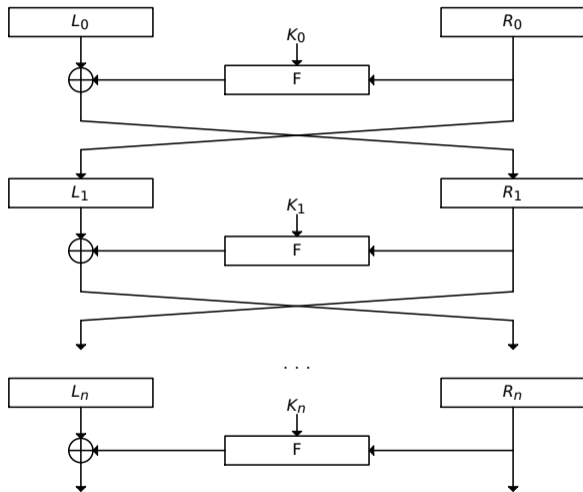

The F Function

- Feistel networks are general-purpose constructs—the security of the cipher depends on the F function
- The heart of the DES F function is the set of S -boxes, which are a set of 64-element arrays that implement a non-linear function of R_i and K_i
- (E expands R by replicating some bits; P is an unkeyed permutation to shuffle things around)
- The S -boxes are crucial to DES' security—but where did they come from? It was long known that they did not appear to be random. Was there an NSA backdoor in the S -boxes?

DES Round Function

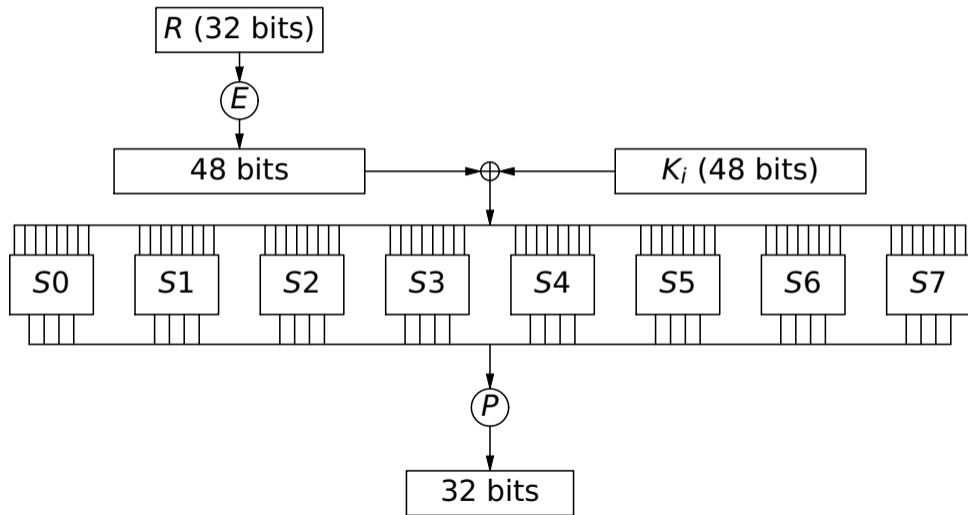

Confusion and Diffusion

- Confusion** Each bit of ciphertext should depend on several—preferably many—bits of the key
- Diffusion** Each bit of the output should depend on many bits of the input. When a single bit of plaintext is changed, statistically half the bits of the ciphertext should change.
- Rounds** No single round can achieve perfect confusion or diffusion. One reason for multiple rounds is to achieve this goal.

Was DES Secure?

- A lot of people distrusted DES—had the NSA sabotaged it?
- After all, the NSA has two roles, protecting US communications—and reading other countries' messages
- Would the NSA permit deployment of a truly strong cipher?
- Whit Diffie and Martin Hellman published an analysis showing that the NSA could afford to build a brute-force DES-cracking engine, but almost no one else could
- And what about the S-boxes?
- A Senate committee concluded that the NSA had not sabotaged the design of DES
- Was that the whole story?

The Official NSA History Discussing DES

~~(S-CCO)~~ The decision to get involved with NBS was hardly unanimous.

EO 1.4.(c)
P.L. 86-36

[REDACTED]

This argued the opposite case – that, as Frank Rowlett had contended since World War II, in the long run it was more important to secure one's own communications than to exploit those of the enemy.¹²¹

~~(FOUO)~~ Once that decision had been made, the debate turned to the issue of minimizing the damage. Narrowing the encryption problem to a single, influential algorithm might drive out competitors, and that would reduce the field that NSA had to be concerned about.

[REDACTED]

[REDACTED] they compromised on a 56-bit

key.¹²²

(From <https://nsarchive2.gwu.edu//NSAEPP/NSAEPP260/nsa-6.pdf>)

Differential Cryptanalysis

- In 1991, two Israeli academics, Eli Biham and Adi Shamir, came up with *differential cryptanalysis*, a very powerful, general-purpose cryptanalysis technique
- They showed that the *S*-boxes were in fact extremely strong—the maximum strength of DES is the key size limit, 2^{56} ; the *S*-boxes provide 2^{54} strength
- This clearly could not have happened by accident
- IBM and/or the NSA knew of differential cryptanalysis (IBM called it *Attack T*) 17 years earlier and designed DES to resist it
- The 56-bit key size limit remained—and we now know that that was intentional

An Alleged Dialog...

DES designer: “You know, we knew about what you call differential cryptanalysis way back when we were designing DES.”

Shamir: “Yes, that’s quite obvious; congratulations.”

DES designer: “Thank you.”

Shamir: “Tell me, have you discovered any stronger attacks on DES since then?”

DES designer: Crickets!



Deep Crack

- The key size issue remained—civilian academics remained convinced that (a) the NSA had shortened the key size, and (b) the NSA was able to read DES
- The US government suggested “escrowed encryption”—there would be an overt backdoor to let the government read encrypted traffic—but no one was interested. . .
- But they kept insisting that DES was secure enough
- In 1998, the Electronic Frontier Foundation settled the issue decisively—by building an open source DES-cracking engine for about \$250,000
- And now factor in Moore’s Law
- As I said, DES is obsolete
- NIST started a new competition, for AES: the Advanced Encryption Standard

AES: The Advanced Encryption Standard

AES was needed for several reasons:

- 1 The first, obviously, is that DES was clearly insecure
- 2 It was possible to iterate DES with three separate keys, in so-called “EDE”—encrypt, decrypt, encrypt—mode, but there were other issues
- 3 DES itself was too slow; 3DES was slower still
- 4 (DES was designed to be implemented in hardware—why? it wasn’t an NSA plot—and things like bit permutations are fast in hardware: just route wires a bit differently. Today, we need speed in software, too, including on 8-bit processors)
- 5 The 64-bit blocksize was too small (stay tuned. . .)

The AES Competition

- NIST announced an open competition; there were 15 submissions from all over the world
- Requirements: 128-bit blocksize, 128-, 192-, and 256-bit keys, secure, simple, efficient
- There were NIST-sponsored public conferences to discuss the candidates
- The NSA evaluated the submissions but did *not* change any part of any submission
- The process got high marks for openness, transparency, and fairness—and there were no accusations of NSA tampering

- Rijndael, by Joan Daemen and Vincent Rijmen, was the choice of most outside experts as well as of NIST
- It's very fast, on low-end and high-end processors
- Internal operations are on bytes, not bits, which contributes to its speed
- It uses 10 rounds for 128-bit keys, 12 rounds for 192 bits, and 14 rounds for 256-bit keys
- It uses a substitution/permutation network, rather than a Feistel design
- AES was formally approved in 2002; as of now, there are no attacks known that are even close to being feasible

Convert a Block to a Matrix

p_0	p_1	p_2	p_3	p_4	p_5	p_6	p_7	p_8	p_9	p_{10}	p_{11}	p_{12}	p_{13}	p_{14}	p_{15}
-------	-------	-------	-------	-------	-------	-------	-------	-------	-------	----------	----------	----------	----------	----------	----------



p_0	p_4	p_8	p_{12}
p_1	p_5	p_9	p_{13}
p_2	p_6	p_{10}	p_{14}
p_3	p_7	p_{11}	p_{15}

Round Operations

SubBytes A non-linear “substitute bytes” operation—each byte is replaced by a different one, using a single S-box for all 16 positions

ShiftRows Rotate the bytes in each row by 0, 1, 2, or 3 positions, depending on the row

MixColumns Apply a linear transform—specified as a matrix multiplication over the proper field—to all four bytes in each column. (Yes, “field”, as in algebra: $GF(2^8)$...))

AddRoundKey Bitwise exclusive-OR of the matrix with the subkey for this round

There are special operations before the first round and for the last round.

Stream Ciphers

- DES and AES are block ciphers—they can't operate until enough bytes have arrived. In some situations, where bytes arrive slowly and asynchronously—think keystrokes on a Teletype—we need something that can encrypt a byte at a time
- For security, though, we want a different key or a different *something* so that the same plaintext letter isn't always mapped to the same ciphertext
- The answer is a *stream cipher*, which stores internal state and hence can change behavior with each encryption
- Typical modern stream ciphers generate a *keystream* which is exclusive-ORed with the plaintext to encrypt or the ciphertext to decrypt



(Photo taken August 12, 2012, at the Connections Museum, Seattle.)

(Teletypes)

- Teleprinters—“Teletype” is a brand name—in their modern form go back about 120 years
- The keyboard and the printer were connected directly to the communications line—if you typed “A”, 0100 0001 would be sent immediately with no protocol; if 0101 1000 was received, the “X” would be printed immediately (actually, it was slightly more complicated, but only slightly)
- The encryptor and decryptor had to work instantly, on one byte at a time
- (Note also the paper tape reader/punch)



(Photo taken August 12, 2012, at the Connections Museum, Seattle.)

- The best-known public stream cipher is RC4, devised by Ron Rivest in 1987 (RC4 stands for “Ron’s Cipher 4”)
- A primary goal: *really fast* encryption—remember how much slower computers were back then, and how DES was inherently slow
- It was originally a trade secret of a company he’d founded—but in 1994, someone leaked or reverse-engineered the code. . .
- RC4 is now considered obsolete—its output is distinguishable from random, and in many situations there are feasible attacks



Note well: stream ciphers are *very hard* to use securely—more on this in a few days

RC4 Pseudocode

The 256-byte array state is initialized from the key, and is changed for each byte generated. Note the XOR in the last line of code, encrypting or decrypting a byte at a time in a variable-length buffer.

```
for(counter = 0; counter < buffer_len; counter++) {  
    x = (x + 1) % 256;  
    y = (state[x] + y) % 256;  
    swap_byte(&state[x], &state[y]);  
  
    xorIndex = (state[x] + state[y]) % 256;  
    buffer_ptr[counter] ^= state[xorIndex];  
}
```

(From the original messages to the Cypherpunks Archive at
<http://cypherpunks.venona.com/archive/1994/09/msg00304.html>)

Encryption and Decryption are the Same Operation

Remember that XOR is its own inverse

$$\begin{aligned}P_i \oplus K_i &= C_i \\C_i \oplus K_i &= (P_i \oplus K_i) \oplus K_i \\&= P_i \oplus (K_i \oplus K_i) \\&= P_i \oplus 0 \\&= P_i\end{aligned}$$

The use of XOR for encryption and decryption of teleprinter traffic goes back to the [1920s](#).

Vernam's One-Time Pad

- Vernam (of AT&T) and Mauborgne (US Army Signal Corps) (re)invented the one-time pad around 1919–20.
- It used a paper tape of true-random characters for keying material; when the operator typed a letter, the paper tape would advance to encrypt that character
- But that much random tape was hard to handle, so Morehouse (AT&T) suggested using two tapes of relatively prime lengths:

$$C_i = P_i \oplus K_{1,i} \oplus K_{2,j}$$

- This is *not* a one-time pad, it's a stream cipher: the actual key, K_i , is derived algorithmically from $K_{1,i}$ and $K_{2,j}$ —and Friedman cracked it
- Morehouse had invented a *stream cipher*

Questions?



(Northern mockingbird eating a wasp, Morningside Park at W 113th St., September 9, 2020)